



EMC Solutions for Microsoft Exchange 2003

Cost-effective e-mail management for midsize enterprises

Achieve your demanding e-mail performance and availability requirements from fully tested and validated solutions built to meet the requirements of midsize enterprise workloads in Exchange 2003 environments.

Business Challenges

With limited resources and increasing demands, today's midsize enterprises need to manage IT costs and reduce the risk of business disruption, while overcoming many of the same challenges as larger companies. These challenges include:

- Meeting Exchange performance and high-availability requirements
- Lowering total cost of storage and operations for Exchange environments
- Managing never-ending mailbox size and database growth
- Rapid recovery of mail, mailboxes, servers, and databases
- Supporting backup requirements with minimal disruption
- Simplifying disaster recovery with tested remote site failback
- Ensuring scalability of e-mail resources
- Adhering to compliance mandates
- Minimizing the complexity of vendor integration

Solution Description

EMC empowers businesses of all sizes to address these challenges. EMC® solutions are backed by rigorous validation and testing in real-world Microsoft Exchange environments. EMC also participates in Microsoft's Exchange Solution Reviewed Program (ESRP). ESRP is a Microsoft Exchange Server program designed to facilitate third-party storage testing and solution publishing for Exchange Server. EMC exceeds all ESRP requirements.

EMC Solutions for Microsoft Exchange 2003 include:

- **EMC Assessment for Microsoft Exchange 2003.** A pre-implementation assessment to properly plan your deployment to ensure faster implementation with reduced risk of business disruption.
 - **EMC Consolidation Solutions for Microsoft Exchange 2003.** EMC offers reference architectures for both iSCSI and Fibre Channel. Both architectures deliver the highest availability, scalability, and performance, as well as compatibility with Microsoft
-

technology. Use iSCSI to leverage existing Ethernet investments and scale to thousands of users. For customers with existing Fibre Channel infrastructure, EMC offers end-to-end 4 Gb Fibre Channel solutions.

- **EMC Backup Solutions for Microsoft Exchange 2003.** This EMC reference architecture integrates the best technologies from EMC—Replication Manager with Microsoft Volume Shadow Copy Services (VSS). Together they eliminate the backup window and enable instant recovery of mail, mailboxes, databases, servers, and sites.
- **EMC Archive Solutions for Microsoft Exchange 2003.** The reference architecture includes EMC EmailXtender® to eliminate the need for hard-to-manage and control .pst files, and automating the movement of older e-mails by archiving them to lower-cost storage devices. The solution delivers policy-based archiving with or without journaling of e-mail. This solution is transparent to the Outlook client, deployed and managed centrally, and supports cached mode.
- **EMC Protection Solutions for Microsoft Exchange 2003.** EMC reference architectures enable you to leverage your existing IP WAN investments. For simple host-based replication, EMC RepliStor® automatically creates mail-store replicas at a remote site for disaster recovery. For total business restart, EMC RecoverPoint provides continuous local and remote replication protection across application environments including Exchange.

EMC and Microsoft's Alliance

Key to every solution engagement is access to EMC and Microsoft expertise, including the sharing of deployment best practices from countless engagements, and reference architecture recommendations to meet specific workload requirements. EMC experience and proven methodologies help you get the results you need, predictably, reliably, and quickly.

- Microsoft turned to EMC when they wanted an Exchange VSS solution for 26,000 of their critical users.
- EMC and Microsoft have a decade-long technical partnership on storage-related APIs, as well as a large staff in Redmond.
- They have a decade-long business partnership, which was recently renewed with an annual \$10M investment focused on joint best practices and solutions.
- EMC is one of 13 Microsoft Global System Integrators
- Twelve-time Microsoft “Partner of the Year” with six gold-level certifications
- EMC participates in the Microsoft Exchange Solution Reviewed Program (ESRP), which is designed to facilitate storage testing and solution publishing for Exchange Server environments.

Accelerating Information Lifecycle Management

EMC's Solutions for Microsoft Exchange are part of a comprehensive family of EMC solutions and services that deliver results throughout the information lifecycle. EMC helps companies of all sizes assess their business objectives to design and align an information infrastructure that reduces risk, lowers cost, and delivers business value.

Reference Architecture – CLARiiON CX Series

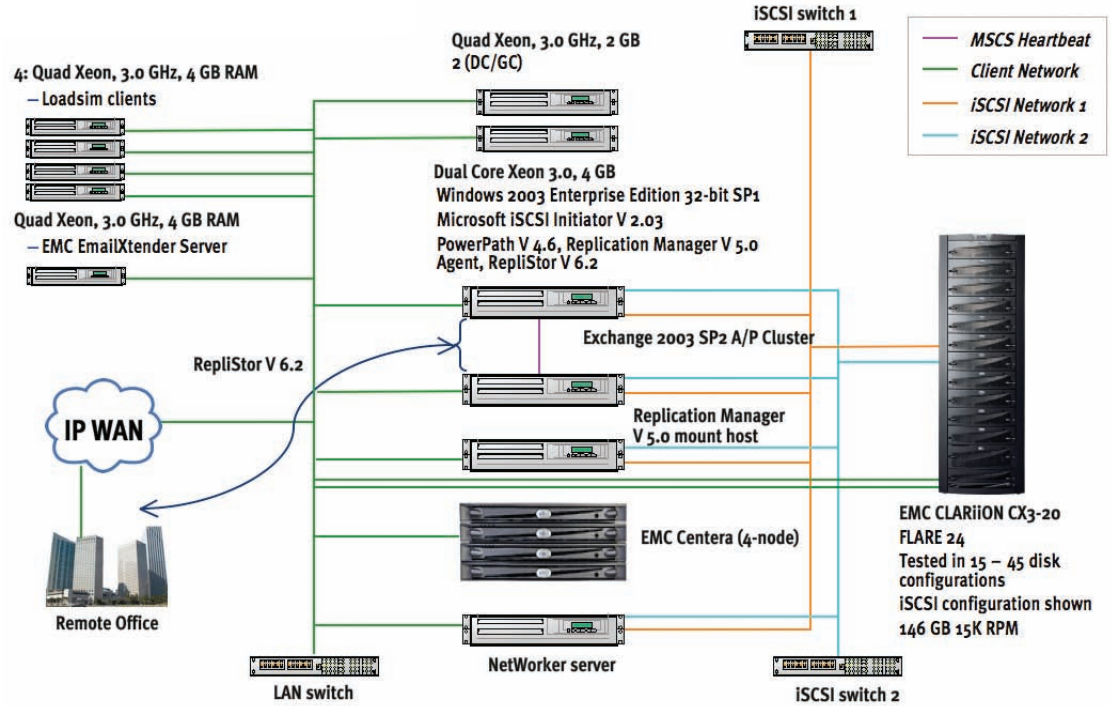

Reference Architecture – Celerra NS Series

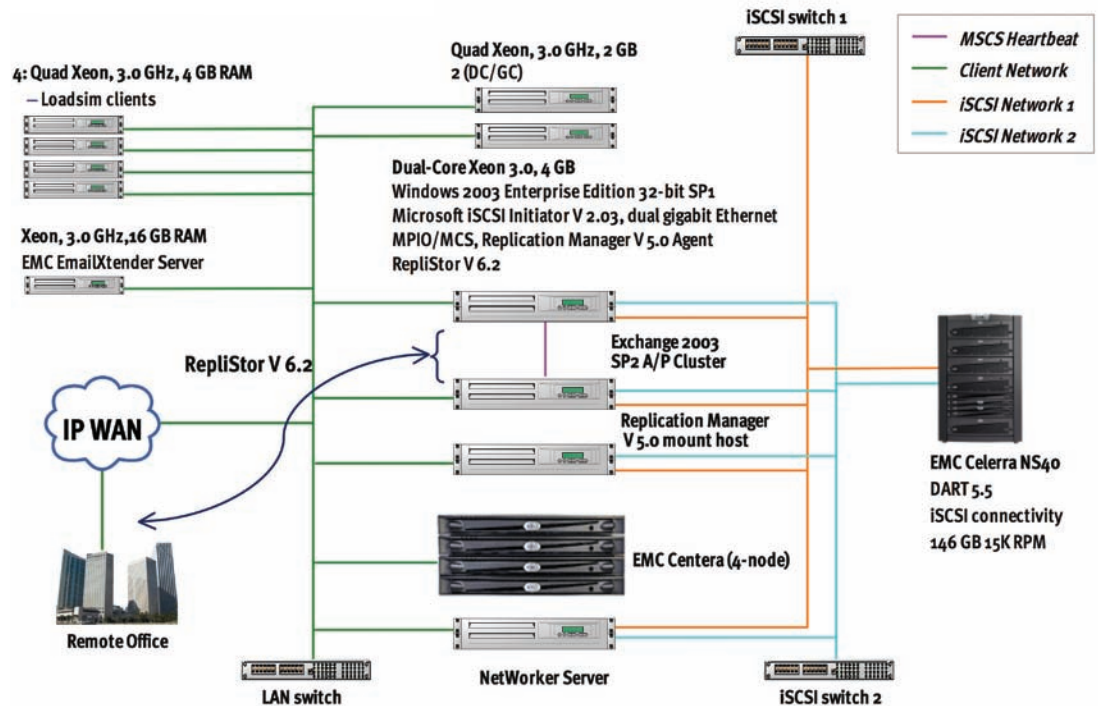

EMC²
where information lives[®]

EMC Corporation
Hopkinton
Massachusetts
01748-9103
1-508-435-1000
In North America 1-866-464-7381

EMC², EMC, EmailXtender, RepliStor, and where information lives are registered trademarks of EMC Corporation. All other trademarks used herein are the property of their respective owners.

© Copyright 2007 EMC Corporation. All rights reserved. Published in the USA. 05/07

H1347.6

Take the Next Step

Ask your EMC sales representative about the full spectrum of solutions and services for midsize enterprises, or visit our website at <http://www.EMC.com/solutions/smb/medium>.